



10th Lecture

**Solution of Plane Systems of Bars
by Means of the Finite Element Method**

Doc. Ing. Antonín Potěšil, CSc.

Contents:

<i>10.1 - Introduction</i>	2
<i>10.2 - Application of FEM</i>	3
<i>10.3 - Types of Boundary Problems</i>	3
<i>10.4 - Formulation of FEM</i>	3
<i>10.5 - Deformation variant of FEM</i>	4
<i>Recommended literature for study of FEM</i>	10
<i>Example of solution of a system of bars</i>	11

10.1 - Introduction

The aim of the lecture is to introduce the students into the problems of the conception of the Finite Element Method (FEM). However, for a deeper insight into this topic it is necessary to study the references at the end of this lecture.

FEM is a numerical method where the driving equations of the problem are represented in a matrix shape, which is convenient for solution by computers. At the same time, the investigated area of the body is idealized by means of suitably arranged small sub-areas called **finite elements (elements)**. When being applied on the material continuum (solid or liquid medium rather than the medium consisting of discrete molecules), the **idealization consists in creating (generating) a mesh of finite number of elements** having limited or (if you like) finite number of degrees of freedom (mobility). The **element** is thus the basic „building unit“ with a defined number of degrees of mobility and can have various shapes and forms. For example a spring, bar, beam, membrane, plate of a given thickness, space 3D element etc., see, for example, Fig.1.

The elements are connected at discrete points (usually corners and sometimes at central points) called **nodes**. Each element has its own characteristic **physical dependence**, which is, for example in **mechanics of solid continuum**, given by the relation between **loading (force) and deformation**, so called **element rigidity** and which is represented by so called **matrix of element rigidity**. This matrix is a function of the element geometry and of mathematical description (model) of physical behaviour of the element material (elastic, plastic, viscoplastic etc. material model). The analysis consists in creation and further solution of the system of equations valid for the idealized area of the body, i.e. for the mesh of elements linked at the nodes, whereas the result of the solution are the displacements of each network nod for the given loading and boundary conditions. As soon as the field of the nodes displacements is determined, strains and stresses can be determined in any place of the investigated idealized area (mesh) of the body by means of the relations displacement – deformation and deformation – stress.

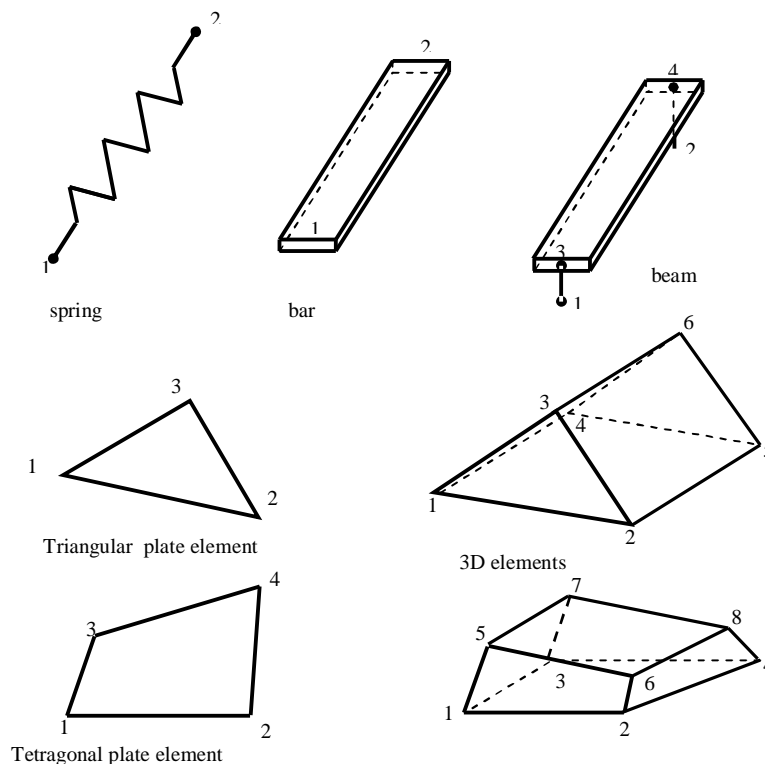

Fig. 10.1

10.2 – FEM Application

Formation and elaboration of the FEM algorithms is linked with the development of the aeronautical and spaceship industry and with the need of deformation and stress analyses of large systems and devices (pipe systems, vehicle bodies, jackets of nuclear reactors etc.). The general character of FEM makes it possible to solve a number of boundary problems (i.e. the problems where a suitable solution is required for the given loading and boundary conditions). Beside the standard elastic stress analysis, this method was applied for plasticity, creep, fatigue, fracture mechanics and dynamical analysis of systems. Moreover, this method has no restrictions in building mechanics; it was successfully applied also in other physically known disciplines such as thermal phenomena, dynamic phenomena in liquid and gas media, electric and magnetic field, mixed problems of field interaction or even piezoelectric phenomena, radiation, chemical phenomena, various kinds of mass transport etc.. As these problems of general and widely comprehensive nature exceed the extent of the present lecture (which is only an introduction into the FEM application in the area of strength analyses of elastic bodies), we shall not deal with FEM in more details. Let us focus on the essential stages of the FEM philosophy that are necessary for gaining primary knowledge of existence of these problems further to the previous lectures.

10.3 – Types of Boundary Problems

Boundary problems of mechanics of solid continuum can be divided in three main groups:

1. Problems of balanced or, if you like, stationary (stable) states, such as solution of displacement or deformation (strain), thermal fields or thermal flows, pressure and speed fields etc..
2. Problems of eigenvalues connected with the notions such as modal analysis, natural frequencies and natural shapes of oscillations, resonance, problems of stability etc.
3. Problems of dynamic and transient performances, e.g. vibrations, transient states stress and strain conditions, e.g. cracking and crack growth, wave spreading, transient thermal phenomena etc..

As was stated above, further the lecture will focus on problems of the balanced states only.

10.4 – FEM Definition

Although the subject of our analysis will only be the problems of machinery and structural mechanics, FEM definition can be introduced in different ways classified according to whether differential equations or variation principles are used. The most important definition of those using differential equations is the FEM deformation variant. Most of the programmes for the analyses of the continuum mechanics problems have been developed by means of this approach mainly for its simplicity, generality and good numerical properties. Only FEM deformation variant will be further considered, although application of a number of other approaches can be shown.

10.5 – FEM deformation variant

FEM deformation variant can be considered as an extension of the method of deformation analysis of systems, which has been used for many years for strut-frames analyses. Moreover it is advantageous from the methodical point of view for explaining basic principles of FEM.

Let us suppose that our task is to analyse a „discrete system“ consisting of bars (elements) in plane, which are joined together or better, hinged (in nodes) - see Fig. 2. The subject of the analysis is to determine displacements of individual hinges (nodes) of the strut-system and forces or stress in bars. Let us isolate one member of the system, e.g. (Bar 1), see Fig. 3. As we consider a plane problem, each node has two degrees of freedom and that in the directions of the global axes of coordinates X and Y . Then each element of the mesh will have four degrees of freedom. Let us denominate displacements of the element nodes q_1, q_2, q_3, q_4 and the forces causing that displacement Q_1, Q_2, Q_3 and Q_4 .

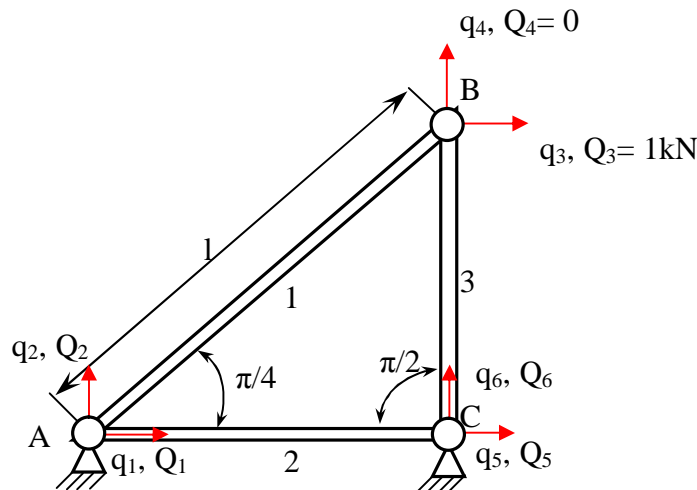

Fig. 10.2

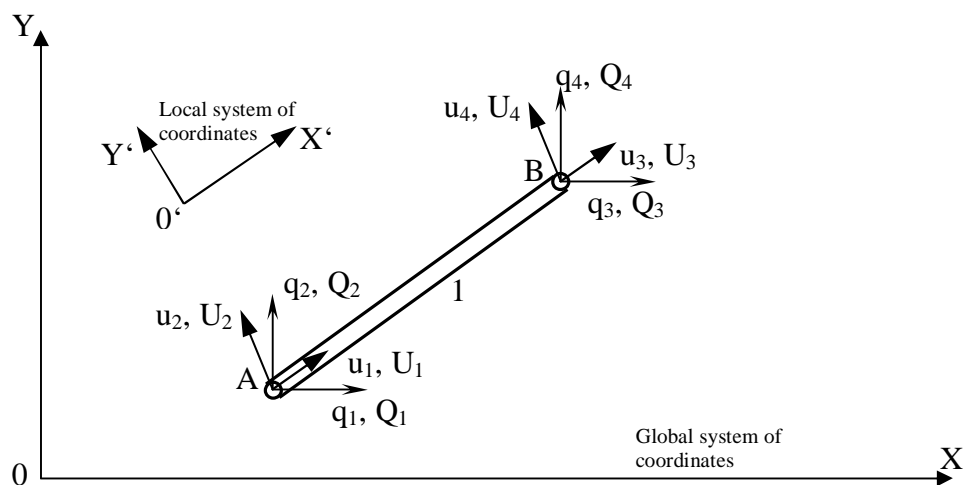

Fig. 10.3

For expressing the relation between the force vector $\{Q\}$ and the displacement vector $\{q\}$ in the global system of coordinates X-Y it is convenient to work at first with the force vectors $\{U\} = \{U_1, U_2, U_3, U_4\}^T$ and the displacement vectors $\{u\} = \{u_1, u_2, u_3, u_4\}^T$ in the local system of coordinates of the given element, i.e. X'-Y', see Fig. 3. By a simple application of the Hooke's law and the principle of superposition, see remark at the end of the text, the relation $\{U\} - \{u\}$ can be expressed as

$$U_1 = \frac{EA}{L}(u_1 - u_3), \quad U_3 = \frac{EA}{L}(u_3 - u_1), \quad (10.1)$$

where E is the Young's module of elasticity, A is the area of the cross section and L is the length of the element. The fraction in the expressions (1) has thus meaning of the length rigidity of the element in the direction of the axis X', which we shall denominate as $k = \frac{EA}{L}$. When isolated, the bar element has no rigidity in the direction of the axis Y', but this rigidity occurs as soon as the element is integrated into the system (mesh) of elements, to which other elements from its neighbourhood contribute. For these reasons it is possible to write for an isolated element, for example 1, a relation between the force vectors and the displacement vectors vis-à-vis the local system of coordinates X'-Y' in the matrix shape

$$\{U\} = [k']_1 \{u\}, \quad (10.2)$$

where the matrix $[k']_1$ is called „local“ **stiffness matrix of the element 1**. It is valid

$$[k']_1 = k \begin{bmatrix} 1 & 0 & -1 & 0 \\ 0 & 0 & 0 & 0 \\ -1 & 0 & 1 & 0 \\ 0 & 0 & 0 & 0 \end{bmatrix}. \quad (10.3)$$

In order to be later able to combine the displacements and/or forces of various elements in the nodes of the mesh, it is necessary to transform the relation (2) into the global system of coordinates X and Y, which is common for all elements of the mesh. Such a transformation is known and easy to be expressed. Between the “local” vector displacements $\{u\} = \{u_1, u_2, u_3, u_4\}^T$ and „global“ vector displacements $\{q\} = \{q_1, q_2, q_3, q_4\}^T$ the following relations are valid:

:

$$\begin{aligned} u_1 &= q_1 \cos a + q_2 \sin a \\ u_2 &= -q_1 \sin a + q_2 \cos a \\ u_3 &= q_3 \cos a + q_4 \sin a \\ u_4 &= -q_3 \sin a + q_4 \cos a \end{aligned} \quad (10.4)$$

If we write the previous relations in the matrix shape, we shall get

$$\{u\} = [T] \{q\} \quad (10.5)$$

where the matrix [T] is the transformation matrix, for which it is valid



$$[T] = \begin{bmatrix} \cos a & \sin a & 0 & 0 \\ -\sin a & \cos a & 0 & 0 \\ 0 & 0 & \cos a & \sin a \\ 0 & 0 & -\sin a & \cos a \end{bmatrix} \quad (10.6)$$

Let us remark that a useful property of the transformation matrix is that its transposition equals its inversion, i.e.

$$[T]^T = [T]^{-1}, \quad (10.7)$$

which will be further exploited.

Analogically, a transformation relation it is valid between the „local“ {U} and the „global“ {Q} forces in the nodes of the element

$$\{U\} = [T]\{Q\}. \quad (10.8)$$

If we introduce expressions (5) and (7) into (2), we shall get

$$[T]\{Q\} = [k]_l [T]\{q\}. \quad (10.9)$$

If we multiply both sides of the previous equation by $[T]^{-1}$ from the left, we shall get

$$[T]^{-1} [T]\{Q\} = [T]^{-1} [k]_l [T]\{q\}. \quad (10.10)$$

Using the property (7) and the fact that $[T]^{-1} [T] = [I]$, where [I] is a unit matrix, we shall get

$$\{Q\} = [T]^T [k]_l [T]\{q\}. \quad (10.11)$$

Product of three matrices $[T]^T [k]_l [T] = [k]_g$ is called the **global stiffness matrix of the element 1**, whereas the expression (11) can be rewritten in the shape

$$\{Q\} = [k]_g \{q\}. \quad (10.12)$$

It can be shown that the global stiffness matrix of the element has the shape

$$[k]_g = k \left[\begin{array}{cc|cc} \cos^2 a & \sin a \cos a & -\cos^2 a & -\sin a \cos a \\ \sin a \cos a & \sin^2 a & -\sin a \cos a & -\sin^2 a \\ \hline -\cos^2 a & -\sin a \cos a & \cos^2 a & \sin a \cos a \\ -\sin a \cos a & -\sin^2 a & \sin a \cos a & \sin^2 a \end{array} \right]. \quad (10.13)$$

Let us notice that the global stiffness matrix of the element is symmetrical vis-à-vis the main diagonal and consists of four sub-matrices that are identical two by two.

So far we have dealt with determination of the rigidity characteristics of one element of the system. It is logical that there has to exist rigidity characteristics of the whole system (of elements) into which every single element contributes thanks to the principle of superposition; it means that there exists a **stiffness matrix of the whole system of elements** – let us denominate it [K]. The process of creation of this matrix for the strut-frame in the fig. 2 is illustrated in the Table 1, where positions of lines and columns in the stiffness matrices of the individual elements



(the second column in the table) is given by the numbers of lines and columns in the stiffness matrix of the system (the third column in the table).

Table 10.1

Contributing element (i)	Line and column of the matrix $[k]_i$	Line and column of the matrix $[K]$
(1)	1 2 3 4	1 2 3 4
(2)	1 2 3 4	1 2 5 6
(3)	1 2 3 4	3 4 5 6

In order to illustrate the process of the matrix $[K]$ creation, let us show its symbolic structure (the numbers in brackets mean a contribution coming from the stiffness matrix $[k]_{(i)}$ of an corresponding element (i), eventually sum of contributions from several, e.g. (1+3)):

	1	2	3	4	5	6
1	(1+2)	(1+2)	(1)	(1)	0	0
2	(1+2)	(1+2)	(1)	(1)	0	0
3	(1)	(1)	(1+3)	(1+3)	(3)	(3)
4	(1)	(1)	(1+3)	(1+3)	(3)	(3)
5	0	0	(3)	(3)	(2+3)	(2+3)
6	0	0	(3)	(3)	(2+3)	(2+3)

It is clear that this process of creation of the system stiffness matrix can be “given over” to a computer, if a suitable algorithm is found, exploiting a geometrical structure of the strut-frame, so called system typology. The driving system of equations for the given strut-frame can then be written in the shape

$$\{Q\} = [K]\{q\}, \quad (14)$$

Where $\{Q\}=\{Q_1, Q_2, Q_3, Q_4, Q_5, Q_6\}^T$ is a vector representing components of the external loadings (in the nodes) including the reactions and $\{q\}=\{q_1, q_2, q_3, q_4, q_5, q_6\}^T$ is a vector of components of displacements of the given strut-frame nodes.

As the system of coordinates represented in the matrix shape (14) describes movement of the strut-frame as a whole (that is: it can be shown that that the matrix $[K]$ is symmetrical and its determinant equals zero), which is not a physical solution sufficient for our needs, it is necessary to “fix” the system, i.e. to prevent its free movement in plane; in other words, it is necessary to re-write the boundary conditions.

For the strut-frame from the fig. 2 these boundary conditions are $q_1=q_2=q_5=q_6=0$. Let us remark that the forces Q_1, Q_2, Q_5 a Q_6 are reactions in the system support and $Q_3=F$ and $Q_4=0$ are loading forces.

Having applied the above-given conditions in (14), the system of equations can be solved with respect to the unknown components of displacement and the forces in bars of the system, stress or eventual reactions can be determined. It is obvious that all these rather elaborate procedures can be realised by a computer, using suitable algorithms, including processing of the results output in a numerical and graphical form.

An example of solution of the plane strut-frames by programmed technologies on present computers is the programme ANSYS that is available in the selected computer classrooms and laboratories of the TUL.

The results gained by this programme for a simple strut-frame in the fig.2 are given in the following tables together with the input data. Graphical output of the computer, see fig.4, allows to get an informative idea about the system deformation, where the node displacements are increased on a scale. Application of the programme ANSYS in various physical applications is a subject of studies in several study programmes of the TUL.

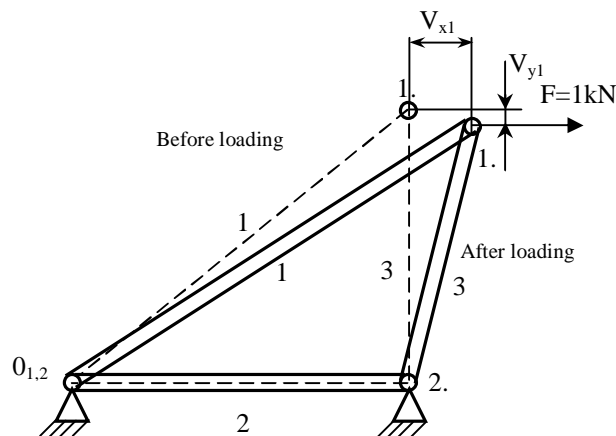

Fig. 10.4

Remark: Let us split deformation behaviour of the element AB in the direction of its axis X' into two cases. First let us suppose that the end B of the element is fixed, i.e. $u_3=0$, see fig. P1a. Then we shall express the force 1U_1 , causing the displacement u_1 , by the Hooke's law as

$${}^1U_1 = \frac{EA}{L} u_1.$$

As the balance equation of the element must be satisfied, it is valid:

$${}^1U_1 + {}^1U_3 = 0, \text{ resp. } {}^1U_3 = -{}^1U_1 = -\frac{EA}{L} u_1.$$

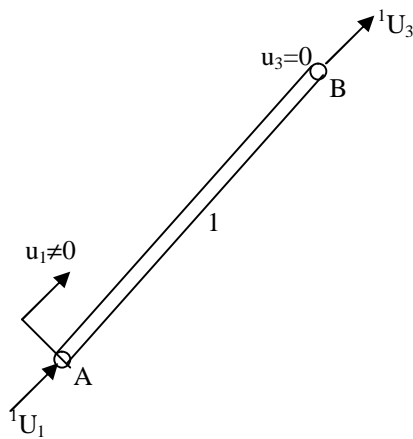

Fig. 10.P1a

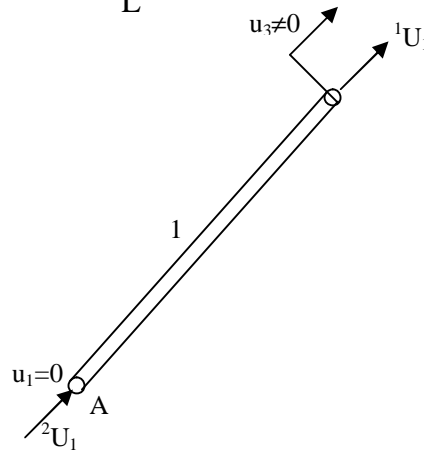

Fig. 10.P1b

If we apply analogical reasoning for the case when $u_1=0$, see fig. P1b, we shall gradually get

$${}^2U_3 = \frac{EA}{L} u_3.$$

$${}^2U_1 + {}^2U_3 = 0, \text{ resp. } {}^2U_1 = -{}^2U_3 = -\frac{EA}{L} u_3.$$

Now let us do a superposition of both partial cases. The resulting forces in the nodes A and B of the element AB (in the positive direction of the axis X') are

$$U_1 = {}^1U_1 + {}^2U_1 = \frac{EA}{L} (u_1 - u_3),$$

$$U_3 = {}^1U_3 + {}^2U_3 = -\frac{EA}{L} (u_1 + u_3) = \frac{EA}{L} (u_3 - u_1).$$



Recommended literature for study of FEM

- [1] Fenner, R. T.: Finite Element Methods for Engineers. Macmillan Press, London, 1975.
- [2] Hinton, E. - Owen, D. R. J.: An Introduction to Finite Element Computations. Pineridge Press, Swansea, 1979.
- [3] Livesley, R. K.: Finite Elements: an introduction for engineers. CPU, Cambridge, 1983.
- [4] Rao, S. S.: The Finite Element Method in Engineering, Pergamon Press, Oxford, 1982.
- [5] Rockey, K. et al.: The Finite Method: a basic introduction. Granada, London 1975.
- [6] Zienkiewicz, O. C.: The Finite Element Method in Engineering Science. McGraw-Hill, London, 1971.
- [7] Kolář, Vl. – Němec, I. – Kanický, V.: FEM – principy a praxe metody konečných prvků. Computer Press, 1997.



Example of solution of a strut-frame

Source code for the solution of the console in the fig. 10.4:

1. Start up the programme system ANSYS
2. Gradually use the following sequence of the instructions with a correct syntax (symbol „!“ is a prefix for and informative commentary that is not necessary to enter, the programme ignores them)

```
fini
/clear

/filename,console      ! work name of the task, so called "jobname"

PI=ACOS(-1)           ! definition of the Ludolf's number for further calculation

! Dimensions of the bars (pipe) cross-sections in [mm]
DOUT=40                ! external diameter
TLT=3                  ! wall thickness
DINN=DOUT-2*TLT       ! internal diameter

! Surface of the bars cross-sections
AREA=0.25*PI*(DOUT*DOUT-DINN*DINN)

! Material - steel
EOC=2e5                ! modulus of elasticity
POIOC=0.3              ! Poisson's number
ROOC=7850e-12          ! density
ALOC=1.2e-5            ! coefficient of temperature dilatation

! Geometric parameters of the system [mm]
L1=1000
L2=1200

! Parameter of loading
FX3=1000               ! [N] loading in the node 3

/PREP7                ! entry into pre-processing

! Choice of the element type (Element Type)
ET,1,LINK1             ! 2-D spar (or truss) element

! Element property – surface of the bar cross-section (so called Real constant)
R,1,AREA

! Setting of material properties
MP,EX,1,EOC
MP,PRXY,1,POIOC
```

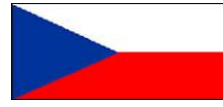

MP,DENS,1,ROOC
 MP,ALPX,1,ALOC

! Construction of the system - direct generation of the element
 ! Generation of the node by the coordinates x, y, (z=0 for a plane problem)
 N,1,0,0,0
 N,2,L1,0,0
 N,3,L1,L2,0

! Generation of the element by means of a node
 E,1,2
 E,2,3
 E,3,1
 ! -----

! Boundary conditions in the system support
 D,1, , , , , UX, UY, , , ,
 D,2, , , , , UY, , , ,

! Loading into the node 3
 F,3,FX,FX3

eplo ! Depiction of the system of elements

fini ! Termination of pre-processing
 ! -----

/solu ! Entry in the solver
 parsave ! Entry of the parameter on the disc into the working directory
 save ! Storing of the database of geometries
 solve ! Activation of the solver
 fini ! Termination of the solver

/post1 ! Activation of the post-processing
 set,first ! Choice of the solution

PLDISP,1 ! Depiction/display of the displacements
 fini ! Termination of the post-processing

/exit,nosave ! Quitting of the programme system Ansys